

D-38 (Cha'Dich) CLASS XIII HEAVY ESCORT CRUISER

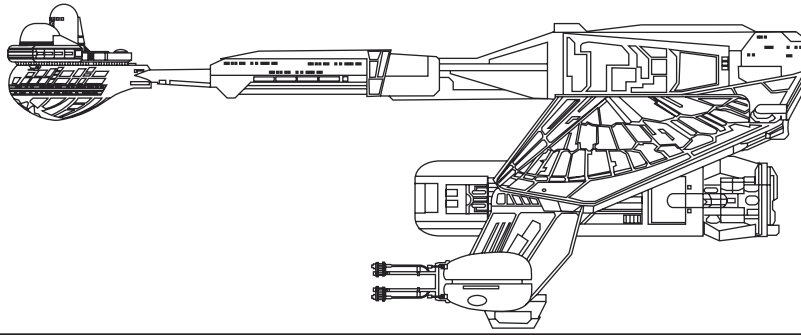

CONSTRUCTION DATA:

Class -	XIII
Model -	A
Date Entering Service -	2290
Number Constructed -	8

HULL DATA:

Superstructure Points -	45
Damage Chart -	C
Size	
Length -	327 m
Width -	302.5 m
Height -	117 m
Weight -	224,770 mt

Cargo

Cargo Units -	230 SCU
Cargo Capacity -	11,500 mt
Landing Capacity -	None

EQUIPMENT DATA:

Control Computer Type -	ZD-10
Transporters -	
Standard 7-person -	4
Combat 28-person -	10
Emergency 14-person -	4
Cargo -	4

OTHER DATA:

Crew -	497
Troops -	300
Passengers -	40
Shuttlecraft -	49

ENGINEERING:

Total Power Units Available -	92
Movement Point Ratio -	5/1
Warp Engine Type -	KWG-2
Number -	2
Power Units Available -	32 ea.
Stress Chart -	I/M
Max Safe Cruising Speed -	Warp 8
Emergency Speed -	Warp 9
Impulse Engine Type -	KIG-1
Power Units Available -	28

WEAPONS AND FIRING DATA:

Beam Weapon Type -	KD-17
Number -	8
Firing Arcs -	2 f/p, 2 f/s, 1 p, 1 s, 2 a
Firing Chart -	X
Maximum Power -	9
Damage Modifiers	
+3	(1-12)
+2	(13-17)
+1	(18-22)
Beam Weapon Type -	KPD-5
Number -	2
Firing Arcs -	2 f
Firing Chart -	O
Maximum Power -	7
Damage Modifiers	
+3	(1-7)
+2	(8-14)
+1	(15-21)
Torpedo Weapon Type -	KP-8
Number -	5
Firing Arcs -	3 f, 2 a
Firing Chart -	S
Power To Arm -	2
Damage -	24

SHIELD DATA:

Deflector Shield Type -	KSQ
Shield Point Ratio -	1/3
Maximum Shield Power -	20

COMBAT EFFICIENCY:

D -	172.4
WDF -	157.0



NOTES:

Known Sphere of Operation: Romulan Borders
 Data Reliability: D
 Major Data Source: Klingon Sector Intelligence

As large as the L-24 class Battleships, these vessels were commissioned into service prior to the introduction of the L-30 Ber'taa Battleships. These ships use almost all state of the art components in their design and the all new components work well together to create a fearsome fighting platform. It is the intension of the Klingon High Command to operate these ships in pairs with a Ber'taa class Battleship, forming the command squadron of all it's front line fleets. The remining L-24s are expected to be eventually be reclassified as Heavy Battlecruisers and form new heavy strike squadrons along the Romulan boarder. Construction of the D-38 is at the rate of 4 per year using the facilities at Taamar and Gunn Re'.